

| **E044088** |
| **E044059** |

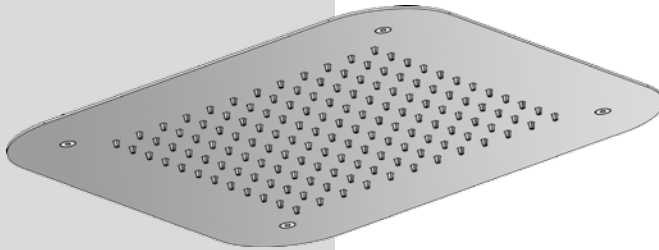

| **E044096** |

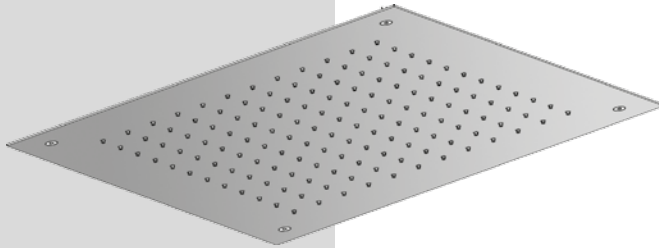

| **E044046** |
| **E044024** |
| **E044067** |

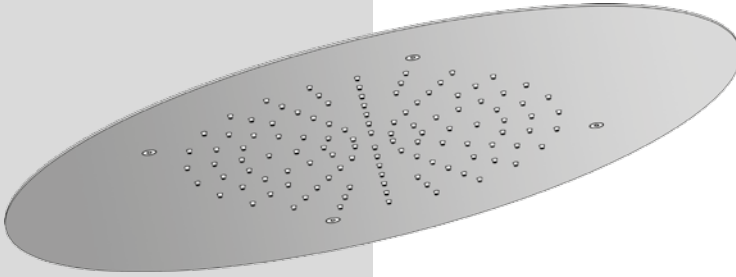

| **E044061** |
| **E044060** |

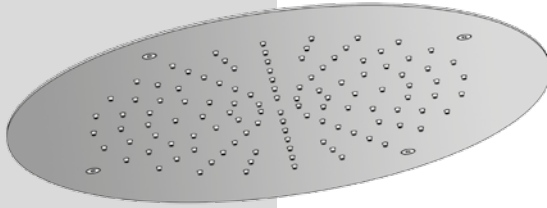

| **E044048** |
| **E044047** |



	E044048	E044047	E044061	E044060	E044046	E044024	E044067	E044096	E044088	E044059
	X1	X1	X1	X1	X1	X1	X1	X1	X1	X1
	X1	X1	-	-	-	-	-	-	-	-
	-	-	X1	X1	-	-	-	-	-	-
	-	-	-	-	X1	X1	X1	-	-	-
	-	-	-	-	-	-	-	X1	-	-
	-	-	-	-	-	-	-	-	X1	X1
	X2	X2	X2	X2	X2	X2	X4	X2	X2	X2
	X1	X1	X1	X1	X1	X1	X2	X1	X1	X1
	X4	X4	X4	X4	X4	X4	X9	X4	X6	X6
	-	-	-	-	-	-	X1	-	-	-
IT Istruzioni di montaggio GB Mounting instructions FR Instructions de montage DE Montageanweisungen ES Instrucciones de montaje	X1	X1	X1	X1	X1	X1	X1	X1	X1	X1



IT | Diagramma di flusso
GB | Flow rate
FR | Le débit
DE | Flussdiagramm
ES | Diagrama de caudal



IT | Indossare protezioni
GB | Wear protection
FR | Porter une protection
DE | Schütze anziehen
ES | Usar protección

X2



IT | Si consiglia di operare insieme ad un'altra persona
GB | We recommend to work with another person
FR | Il est fortement recommandé de travailler avec une autre personne.
DE | Wir empfehlen mit einer anderen Person zu arbeiten
ES | Recomendamos trabajar en conjunto con otra persona



IT | Pressione d'uso
GB | Operating pressure
FR | Pression d'utilisation
DE | Betriebsdruck
ES | Presión de uso



IT | Temperatura dell'acqua
GB | Water temperature
FR | Température de l'eau
DE | Wassertemperatur
ES | Temperatura del agua



IT | Caratteristiche idrauliche
GB | Plumbing specifications
FR | Caractéristiques hydrauliques
DE | Hydraulische Eigenschaften
ES | Características hidráulicas

| E044048 |

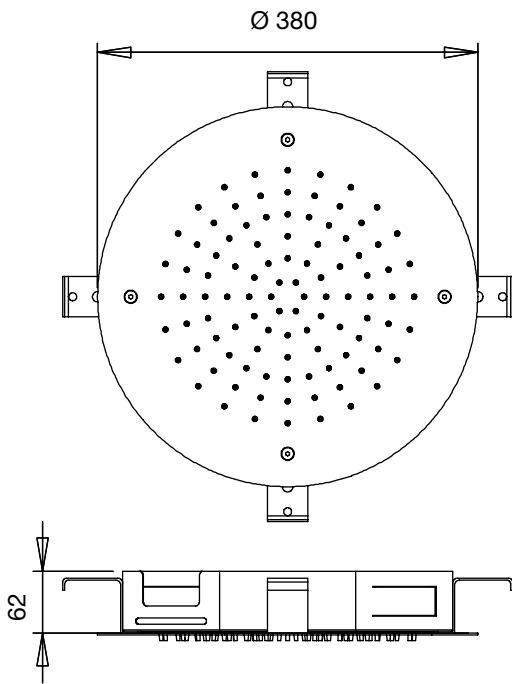

- ◆— | **IT** | Portata l/min. pioggia
- | **GB** | l/min. rain flow
- | **FR** | Débit l/min. pluie
- | **DE** | l/min. Regenfluss
- | **ES** | Caudal l/min. lluvia



MIN 1 Bar
MAX 5 Bar
BEST 3 Bar



MAX 70° C
BEST 38°/40° C

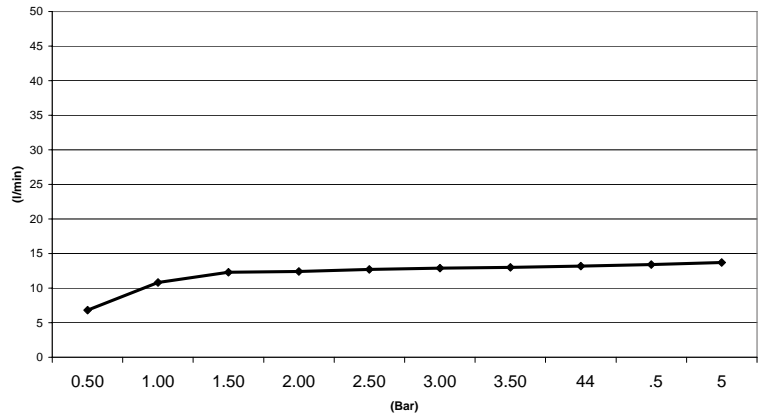

	Pressione Dinamica (bar) / Portata (Litri/min)									
Bar	0,50	1,00	1,50	2,00	2,50	3,00	3,50	4	4,5	5
—◆—	6,8	10,8	12,3	12,4	12,7	12,9	13	13,2	13,4	13,7

| E044047 |

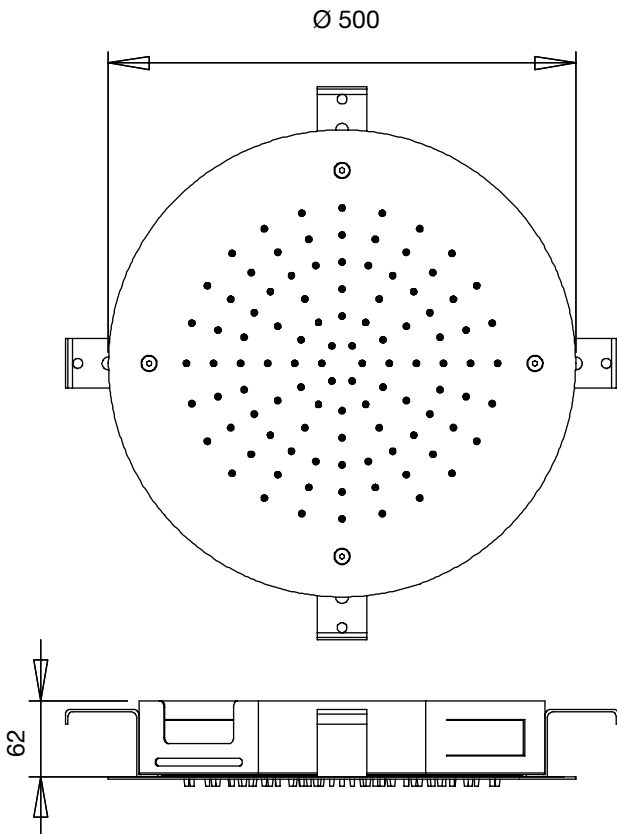

- ◆— | **IT** | Portata l/min. pioggia
- | **GB** | l/min. rain flow
- | **FR** | Débit l/min. pluie
- | **DE** | l/min. Regenfluss
- | **ES** | Caudal l/min. lluvia



MIN 1 Bar
MAX 5 Bar
BEST 3 Bar



MAX 70° C
BEST 38°/40° C

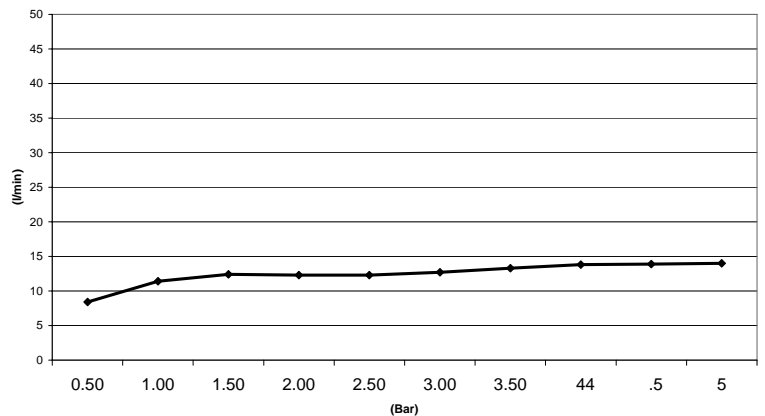

	Pressione Dinamica (bar) / Portata (Litri/min)									
Bar	0,50	1,00	1,50	2,00	2,50	3,00	3,50	4	4,5	5
—◆—	8,4	11,4	12,4	12,3	12,3	12,7	13,3	13,8	13,9	14

| E044061 |

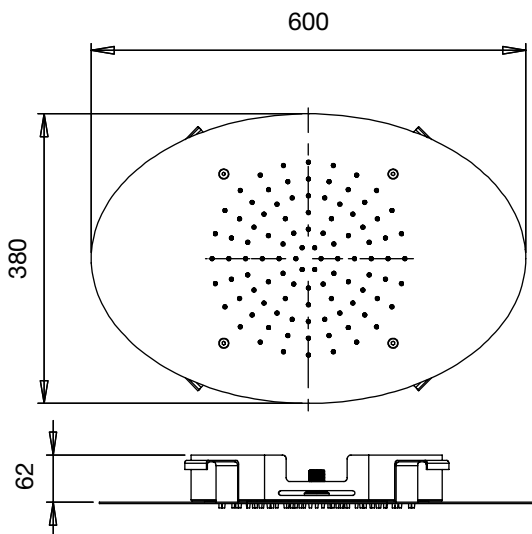

- ◆— IT | Portata l/min. pioggia
- GB | l/min. rain flow
- FR | Débit l/min. pluie
- DE | l/min. Regenfluss
- ES | Caudal l/min. lluvia



MIN 1 Bar
MAX 5 Bar
BEST 3 Bar



MAX 70° C
BEST 38°/40° C

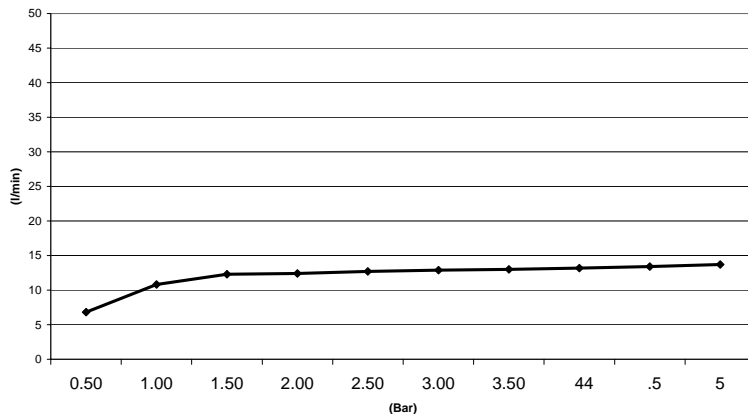

	Pressione Dinamica (bar) / Portata (Litri/min)									
Bar	0,50	1,00	1,50	2,00	2,50	3,00	3,50	4	4,5	5
—◆—	6,8	10,8	12,3	12,4	12,7	12,9	13	13,2	13,4	13,7

| E044060 |

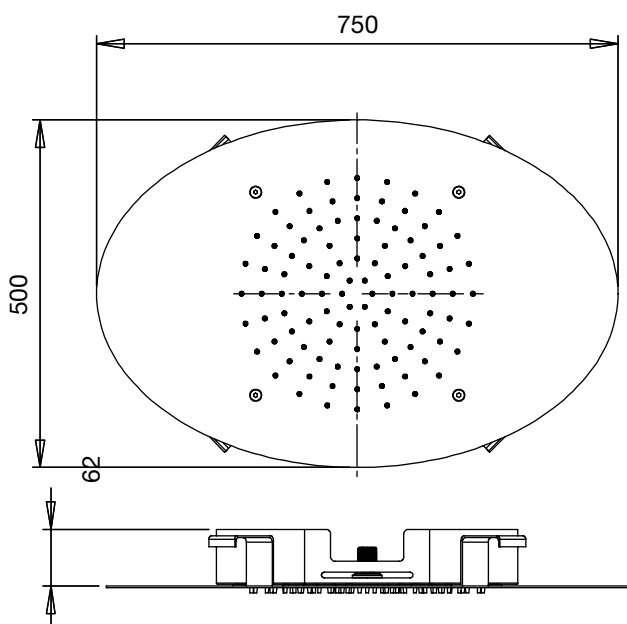

- ◆— IT | Portata l/min. pioggia
- GB | l/min. rain flow
- FR | Débit l/min. pluie
- DE | l/min. Regenfluss
- ES | Caudal l/min. lluvia



MIN 1 Bar
MAX 5 Bar
BEST 3 Bar



MAX 70° C
BEST 38°/40° C

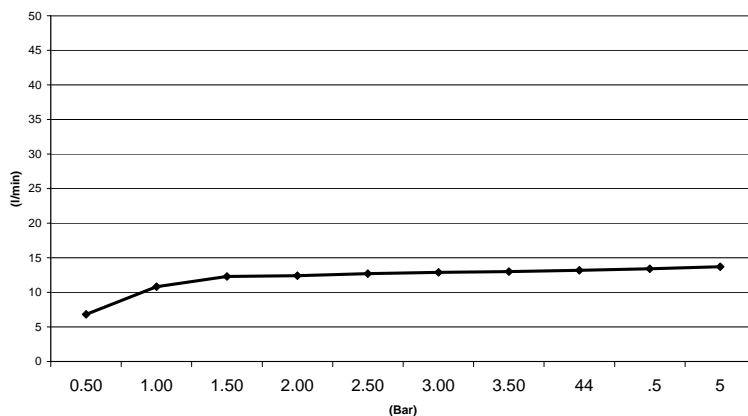

	Pressione Dinamica (bar) / Portata (Litri/min)									
Bar	0,50	1,00	1,50	2,00	2,50	3,00	3,50	4	4,5	5
—◆—	8,4	11,4	12,4	12,3	12,3	12,7	13,3	13,8	13,9	14

| E044046 |

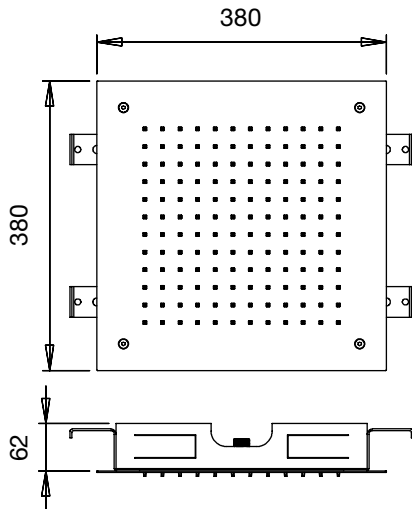

- ◆ IT | Portata l/min. pioggia
- ◆ GB | l/min. rain flow
- ◆ FR | Débit l/min. pluie
- ◆ DE | l/min. Regenfluss
- ◆ ES | Caudal l/min. lluvia



MIN 1 Bar
MAX 5 Bar
BEST 3 Bar



MAX 70° C
BEST 38°/40° C

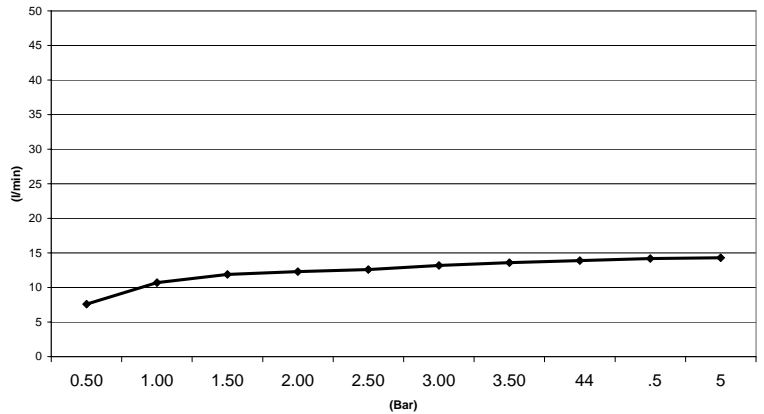

	Pressione Dinamica (bar) / Portata (Litri/min)									
Bar	0,50	1,00	1,50	2,00	2,50	3,00	3,50	4	4,5	5
◆	7,6	10,7	11,9	12,3	12,6	13,2	13,6	13,9	14,2	14,3

| E044024 |

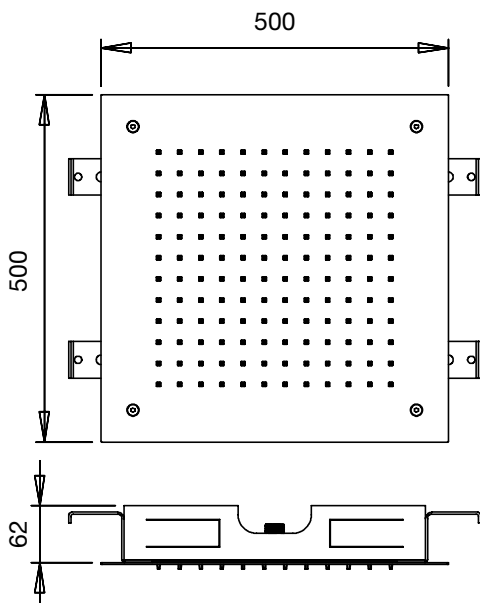

- ◆ IT | Portata l/min. pioggia
- ◆ GB | l/min. rain flow
- ◆ FR | Débit l/min. pluie
- ◆ DE | l/min. Regenfluss
- ◆ ES | Caudal l/min. lluvia



MIN 1 Bar
MAX 5 Bar
BEST 3 Bar



MAX 70° C
BEST 38°/40° C

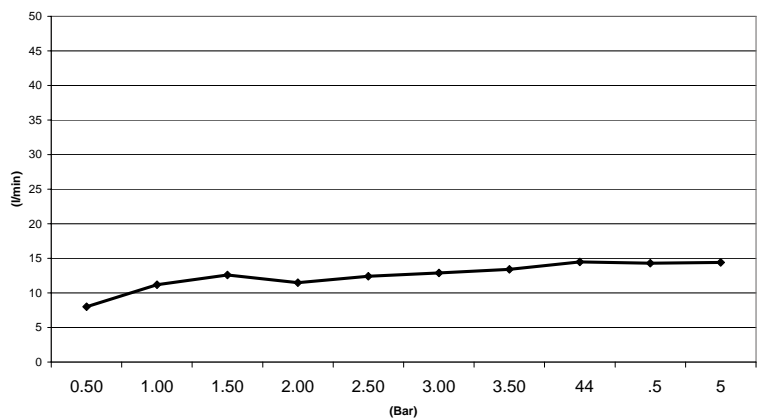

	Pressione Dinamica (bar) / Portata (Litri/min)									
Bar	0,50	1,00	1,50	2,00	2,50	3,00	3,50	4	4,5	5
◆	8	11,2	12,6	11,5	12,4	12,9	13,4	14,5	14,3	14,4

| E044067 |

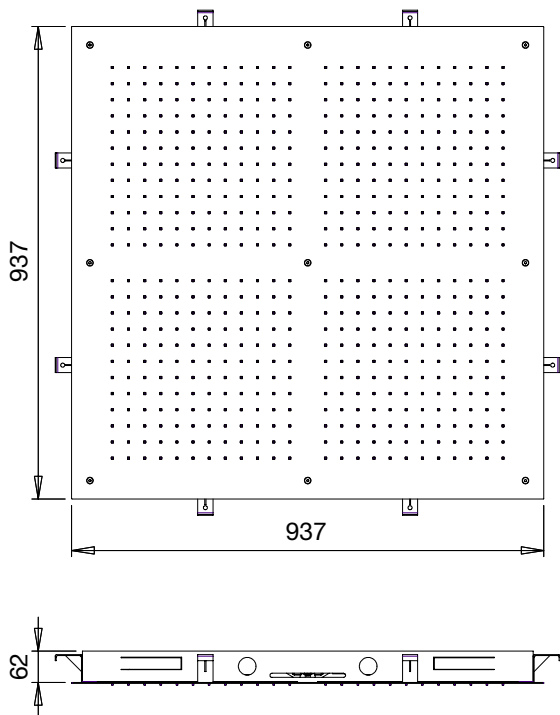

MIN 40 l/min

- ◆ | **IT** | Portata l/min. pioggia
- ◆ | **GB** | l/min. rain flow
- ◆ | **FR** | Débit l/min. pluie
- ◆ | **DE** | l/min. Regenfluss
- ◆ | **ES** | Caudal l/min. lluvia



MIN 1 Bar
MAX 5 Bar
BEST 3 Bar



MAX 70° C
BEST 38°/40° C

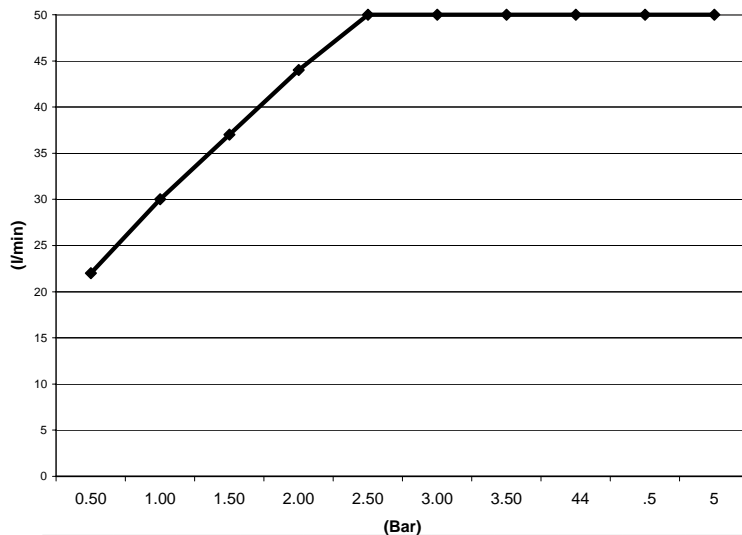

Pressione Dinamica (bar) / Portata (Litri/min)	
Bar	0,50 1,00 1,50 2,00 2,50 3,00 3,50 4 4,5 5
◆	22 30 37 44 50 50 50 50 50 50

| E044096 |

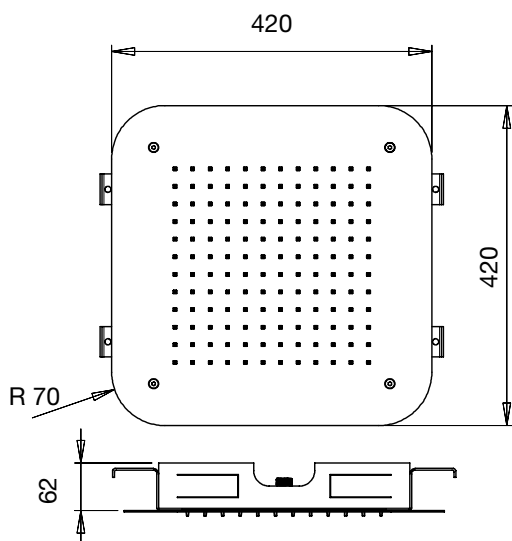

MIN 40 l/min

- ◆ | **IT** | Portata l/min. pioggia
- ◆ | **GB** | l/min. rain flow
- ◆ | **FR** | Débit l/min. pluie
- ◆ | **DE** | l/min. Regenfluss
- ◆ | **ES** | Caudal l/min. lluvia



MIN 1 Bar
MAX 5 Bar
BEST 3 Bar



MAX 70° C
BEST 38°/40° C

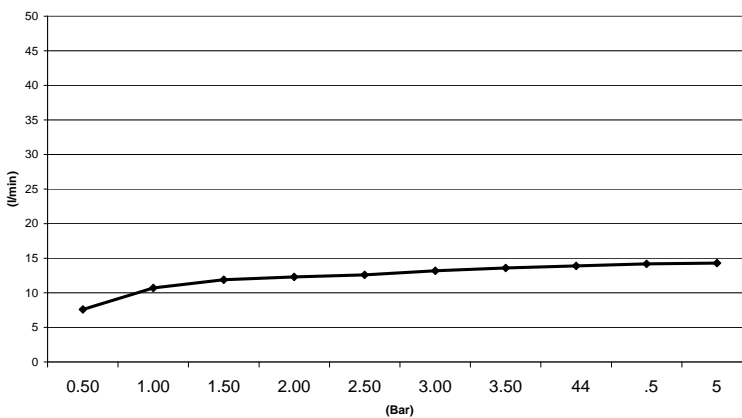

Pressione Dinamica (bar) / Portata (Litri/min)	
Bar	0,50 1,00 1,50 2,00 2,50 3,00 3,50 4 4,5 5
◆	7,6 10,7 11,9 12,3 12,6 13,2 13,6 13,9 14,2 14,3

| E044088 |

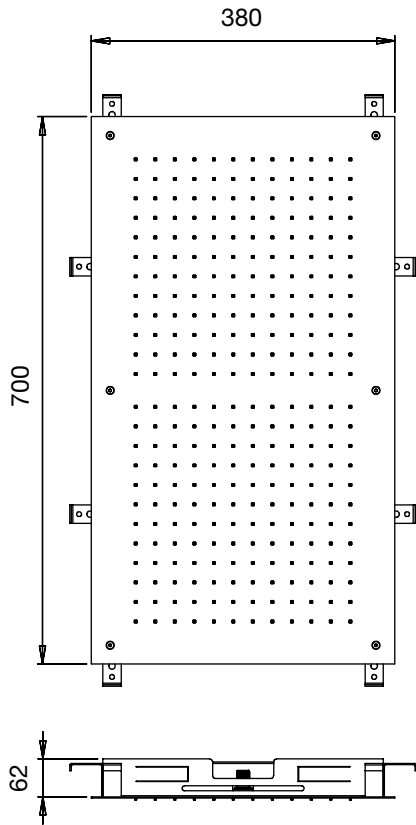

MIN 20 l/min

- ◆ IT | Portata l/min. pioggia
- ◆ GB | l/min. rain flow
- ◆ FR | Débit l/min. pluie
- ◆ DE | l/min. Regenfluss
- ◆ ES | Caudal l/min. lluvia



MIN 1 Bar
MAX 5 Bar
BEST 3 Bar



MAX 70° C
BEST 38°/40° C

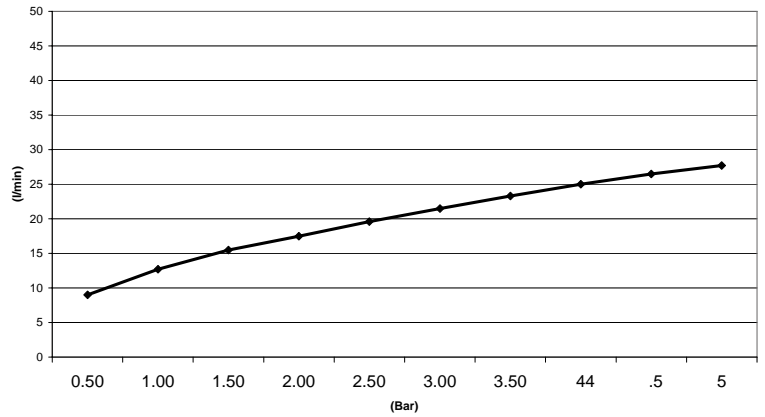

	Pressione Dinamica (bar) / Portata (Litri/min)									
Bar	0,50	1,00	1,50	2,00	2,50	3,00	3,50	4	4,5	5
◆	9	12,7	15,5	17,5	19,6	21,5	23,3	25	26,5	27,7

| E044059 |

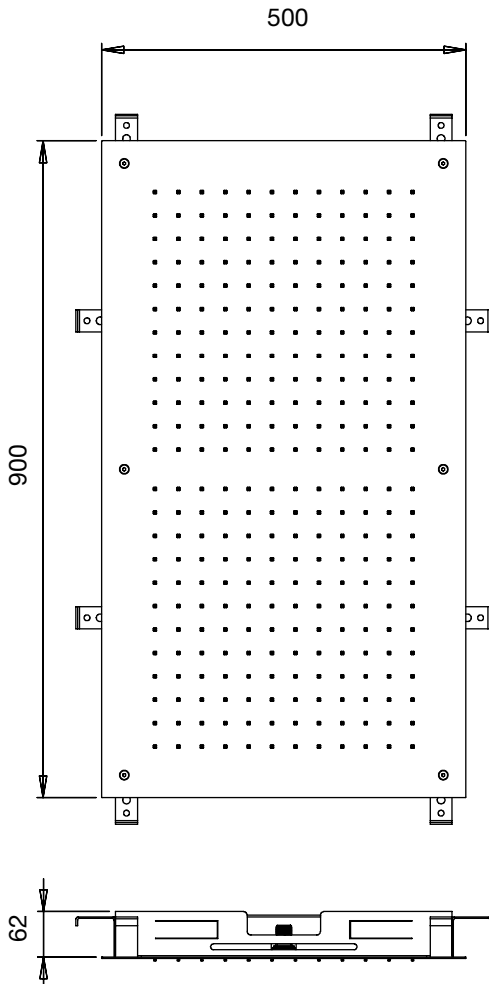

MIN 20 l/min

- ◆ IT | Portata l/min. pioggia
- ◆ GB | l/min. rain flow
- ◆ FR | Débit l/min. pluie
- ◆ DE | l/min. Regenfluss
- ◆ ES | Caudal l/min. lluvia



MIN 1 Bar
MAX 5 Bar
BEST 3 Bar



MAX 70° C
BEST 38°/40° C

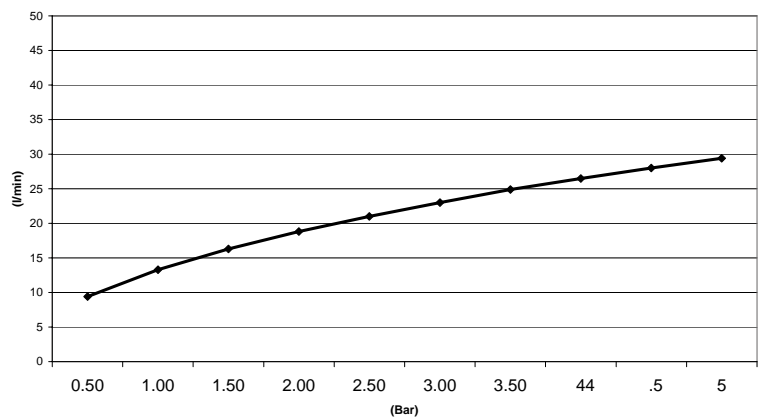

	Pressione Dinamica (bar) / Portata (Litri/min)									
Bar	0,50	1,00	1,50	2,00	2,50	3,00	3,50	4	4,5	5
◆	9,4	13,3	16,3	18,8	21	23	24,9	26,5	28	29,4

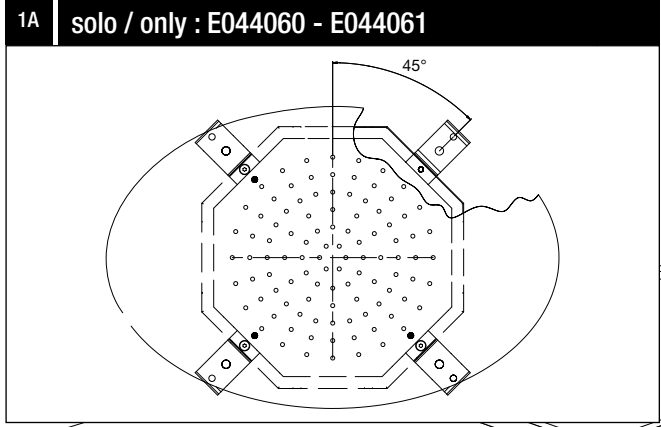
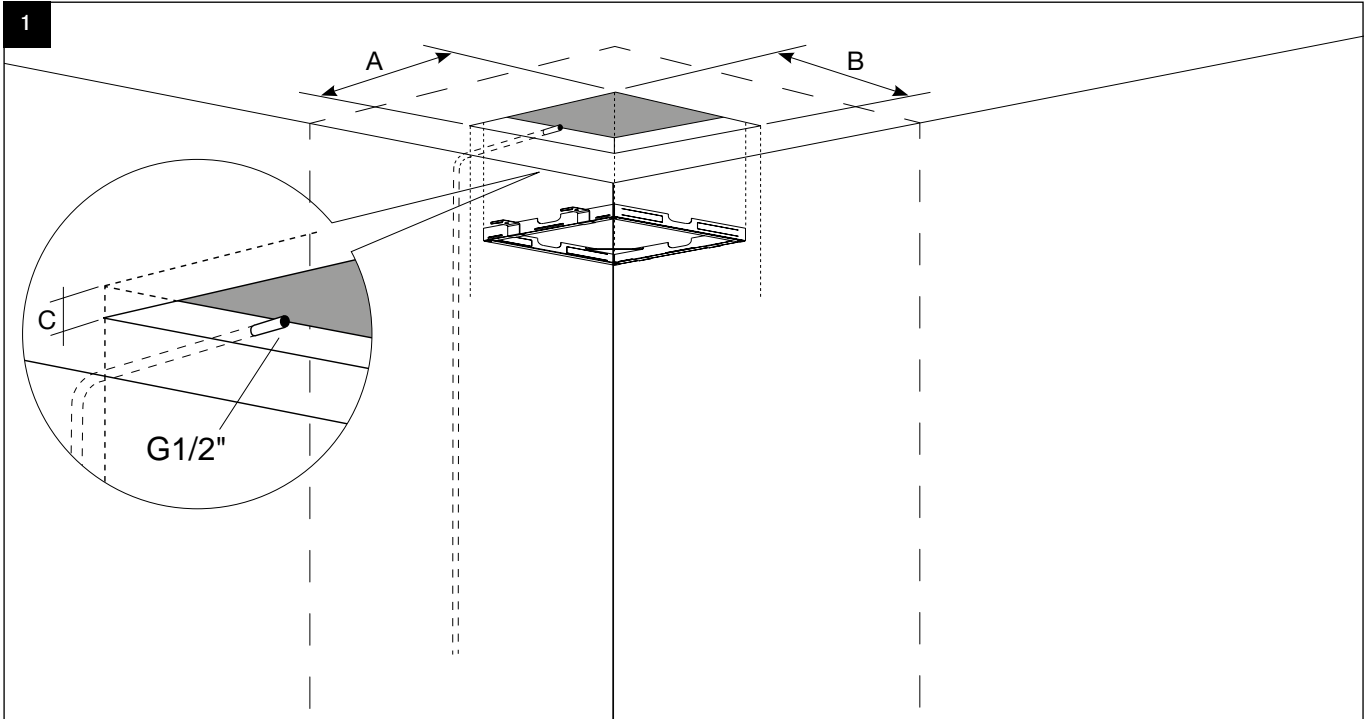

codice	A	B	C	D
E044048			min. 7,5 cm	45 cm
E044047			min. 7,5 cm	54 cm
E044061			min. 7,5 cm	45 cm
E044060			min. 7,5 cm	54 cm
E044046	45 cm	45 cm	min. 7,5 cm	
E044024	57 cm	57 cm	min. 7,5 cm	
E044067	100 cm	100 cm	min. 6,5 cm	
E044096	45 cm	45 cm	min. 7,5 cm	
E044088	77 cm	45 cm	min. 7,5 cm	
E044059	57 cm	97 cm	min. 7,5 cm	

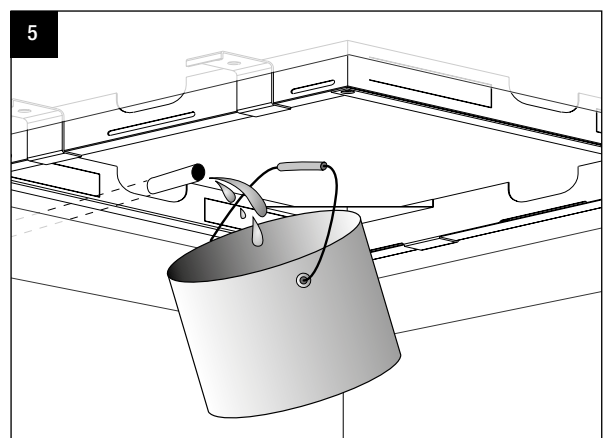
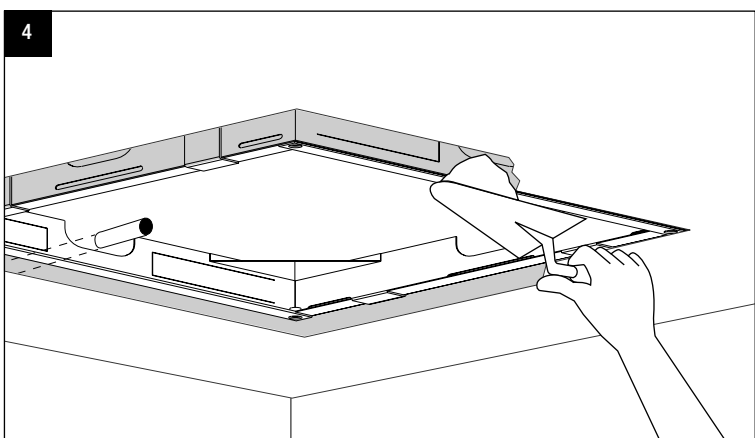
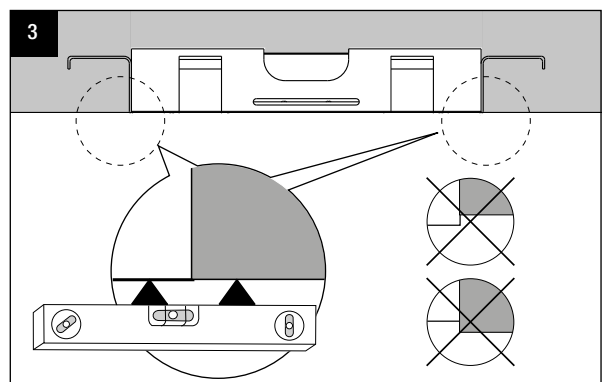
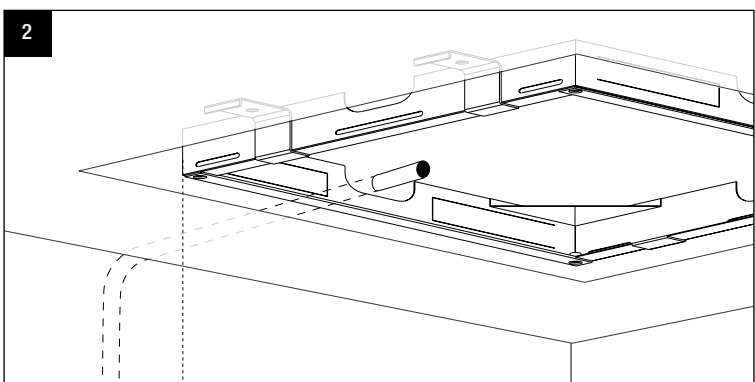

1B solo / only : E044067

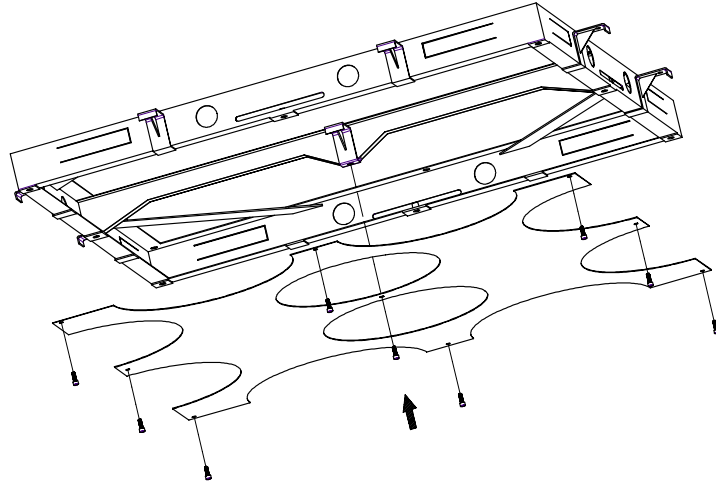

1C

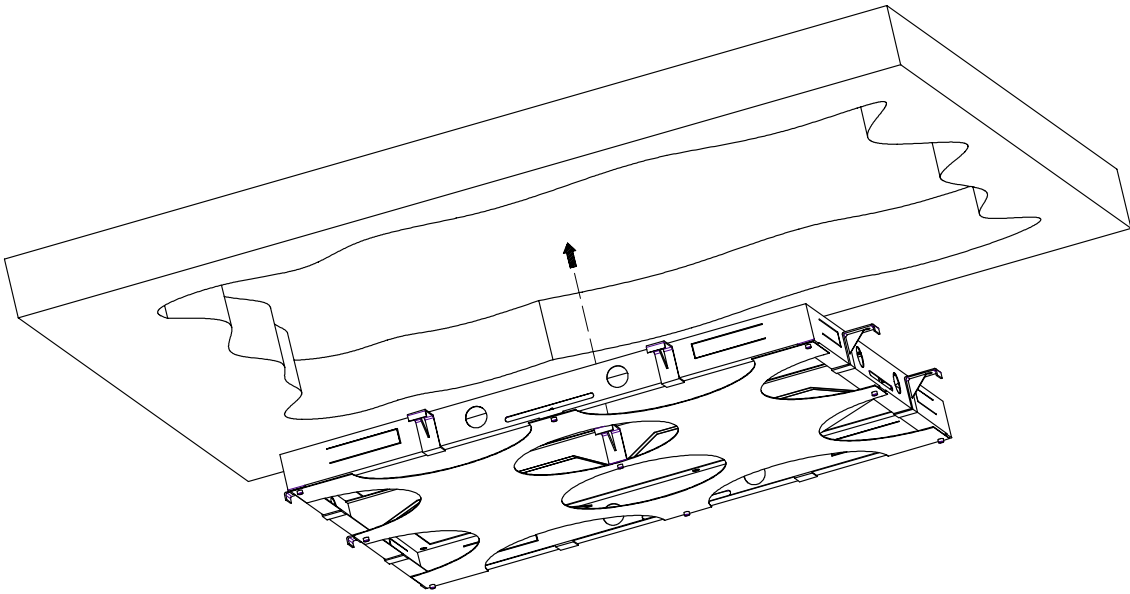

1D

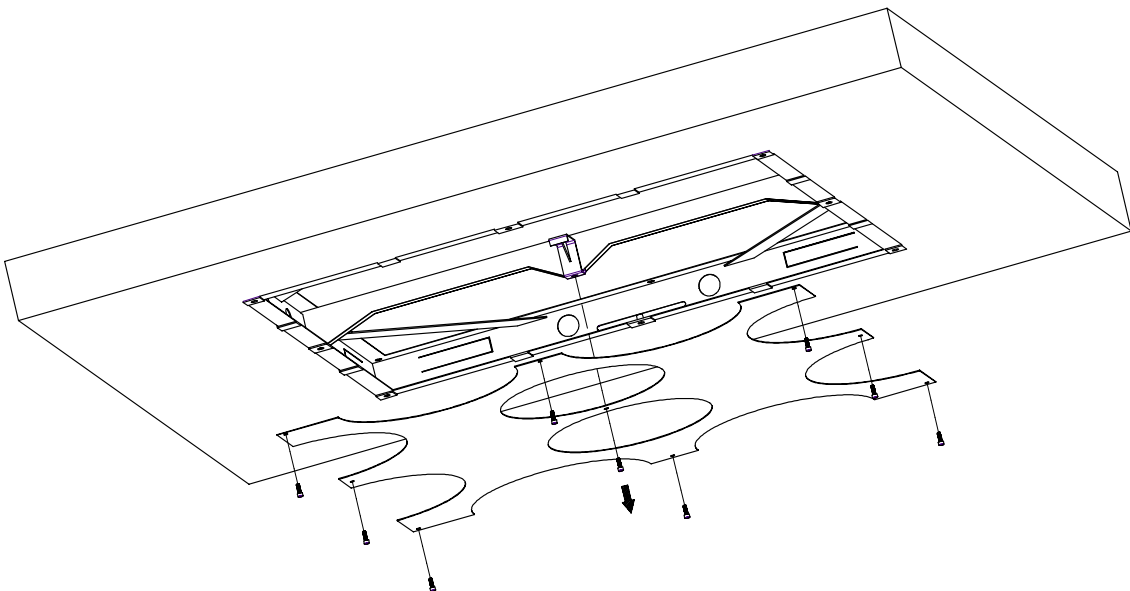

6

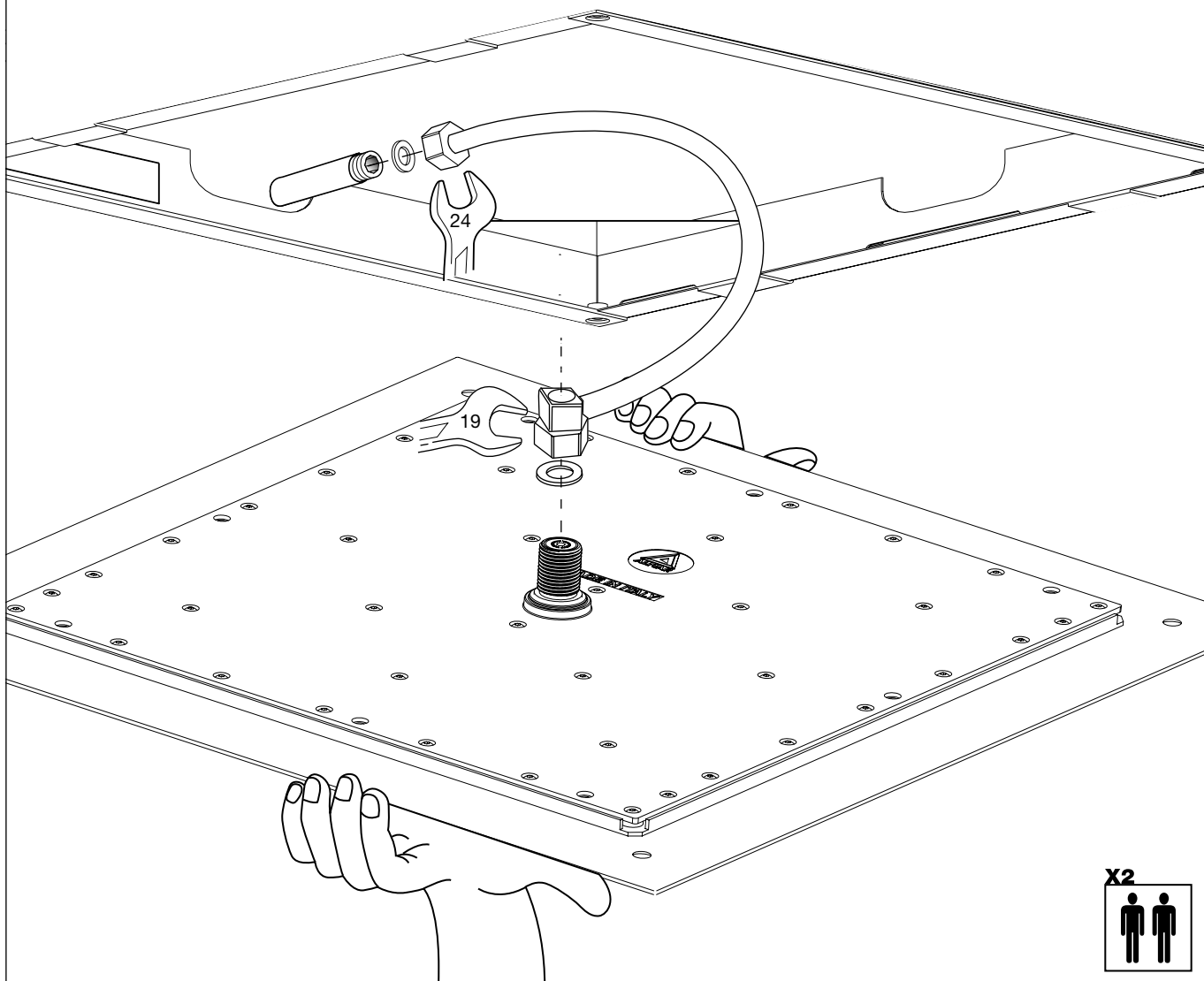

7

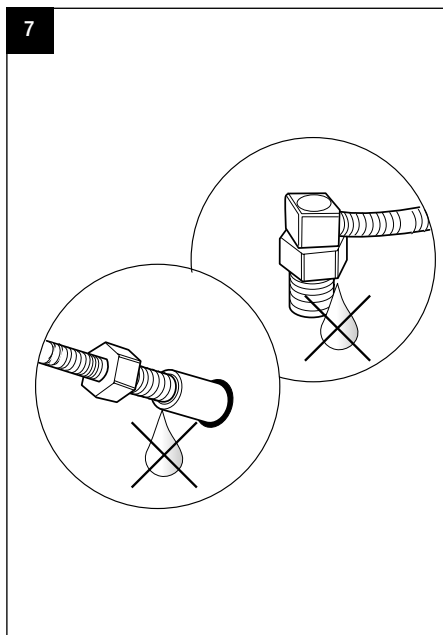

8

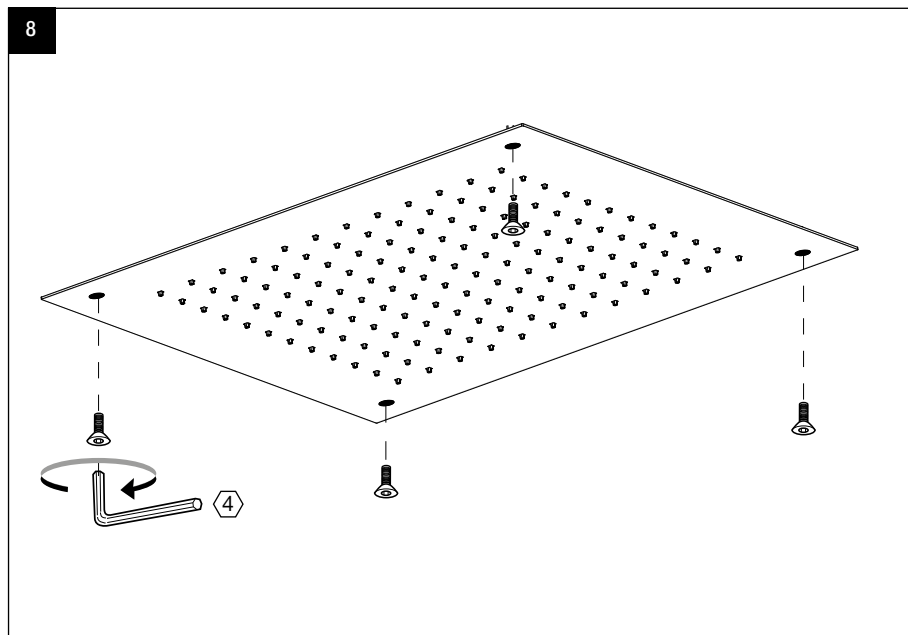

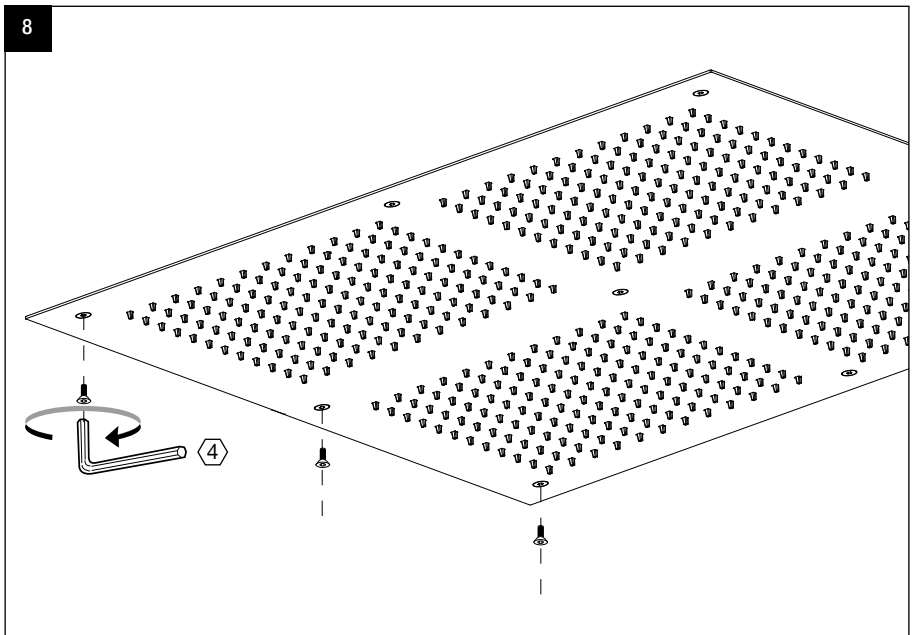
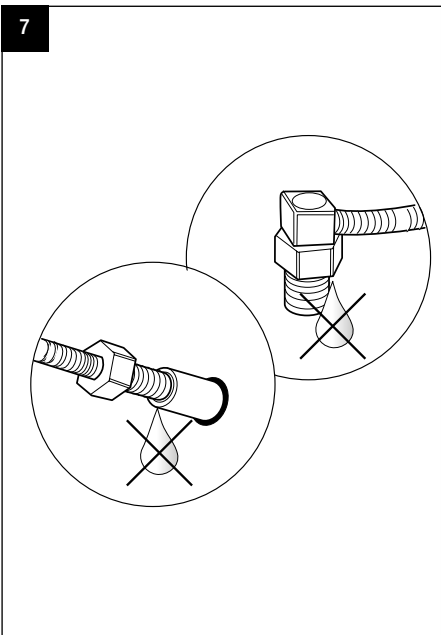
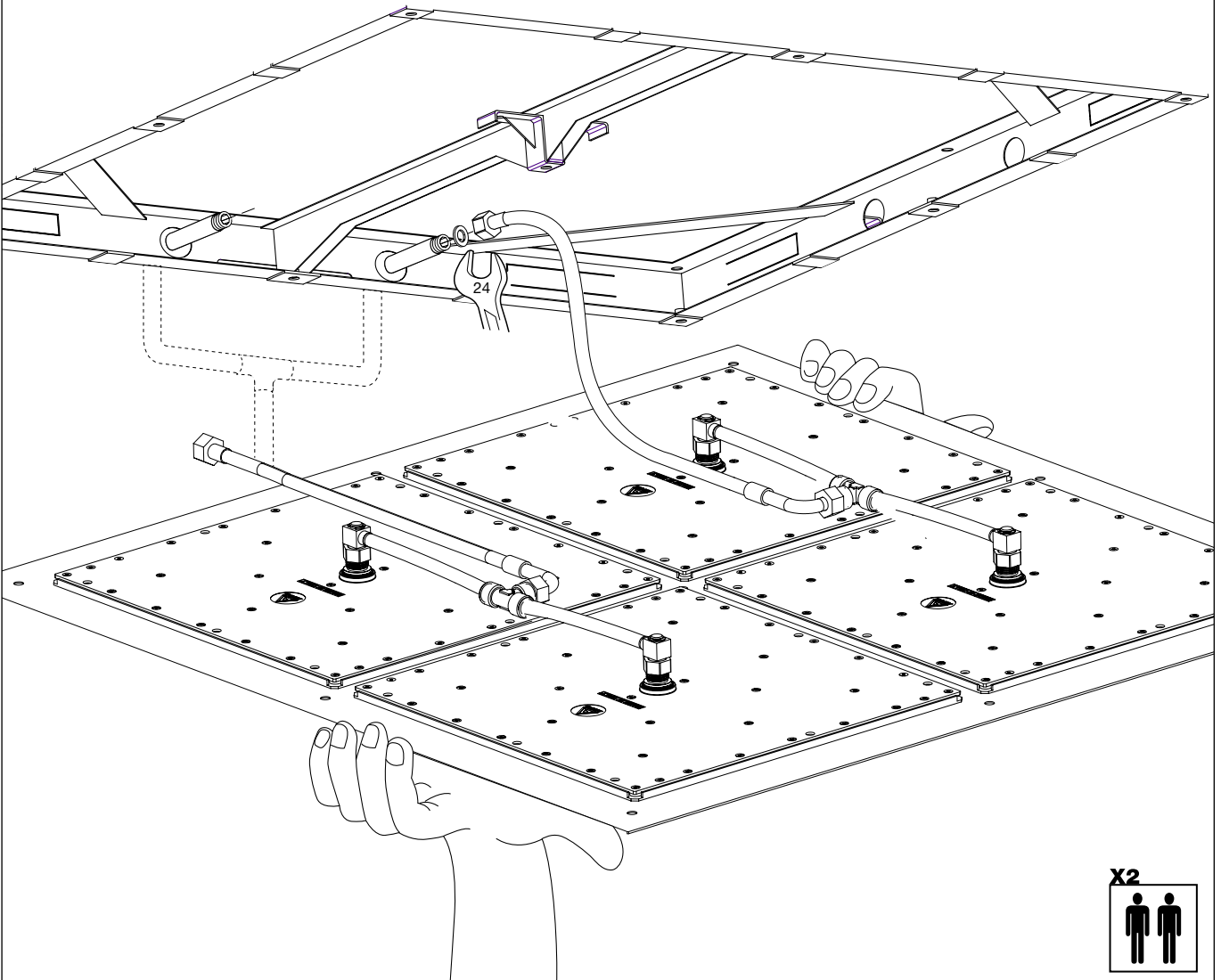

Cleaning

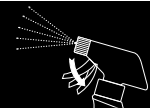

Suggerimenti per la pulizia
Cleaning Tips
Conseils de nettoyage
Reinigung Tipps
Consejos de limpieza

MCZ 5/11

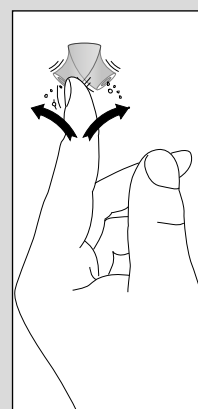
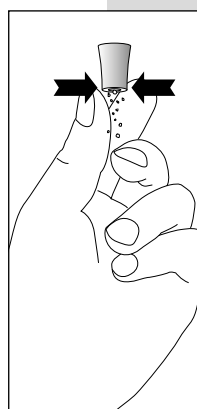
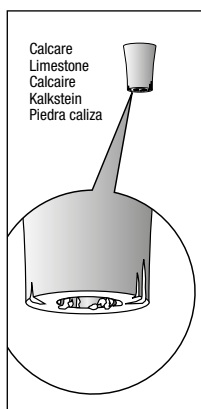
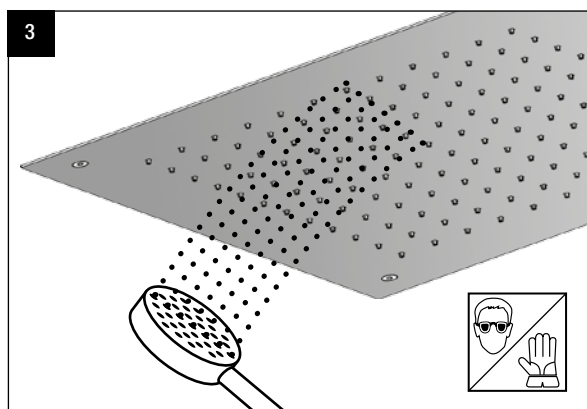
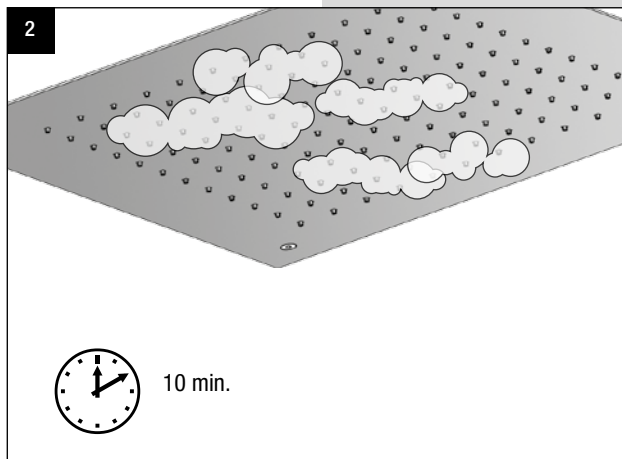
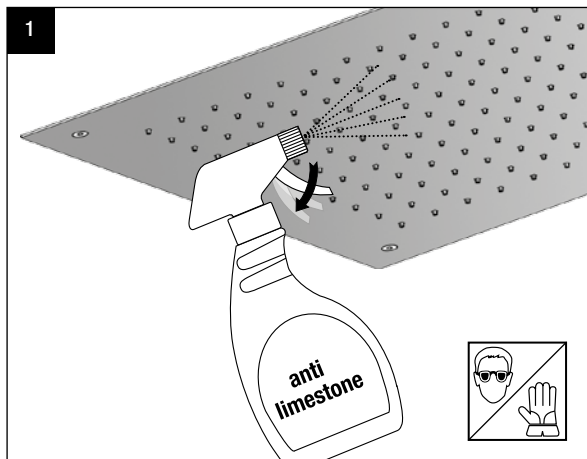

Optional

Kit di sicurezza per controsoffittature non portanti
Kit de sécurité pour les faux-plafonds pas auto-portants
Sicherheitskit für nicht tragende zwischendecke
Security kit for non-bearing false ceiling
Kit de seguridad para encastrar a techo sin apoyo

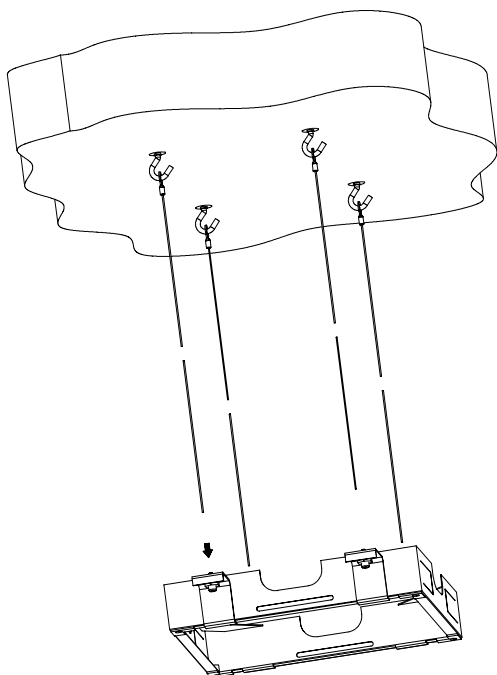

C083019.-